

**520nm Green Diode Low Noise Laser**



†**Specifications**

|  |                            |                       |
|--|----------------------------|-----------------------|
| Product Code                           | SSL - 520 - XXXX - LN      |                       |
| Wavelength [ nm ]                      | 520 ±3                     |                       |
| Output Power [ mW ]                    | 1 - 100                    | 1 - 1000              |
| Transverse Mode                        | TEM <sub>00</sub> / CW     | TE <sub>00</sub> / CW |
| Operating Temperature [ °C ]           | +10 - +35                  |                       |
| Storage Temperatures [ °C ]            | -10 - +45                  |                       |
| Warm-up Time [ minutes ]               | < 5                        |                       |
| Power Stability [ rms, over 4 hours ]  | 5%, 3%, 1%                 |                       |
| M <sup>2</sup> Factor                  | < 2.0                      | < 5                   |
| Beam Diameter At The Aperture [ mm ]   | ~ 2.5                      | ~ 3.0 × 2.0           |
| Beam Divergence, Full Angle [ mrad ]   | < 1.0                      | < 1.2                 |
| Spectral Linewidth [ nm ]              | < 1.0                      |                       |
| Polarization Ratio                     | > 50 : 1                   |                       |
| Point Stability After Warm-up [ mrad ] | < 0.05                     |                       |
| Noise of Amplitude [ rms ]             | < 1%                       |                       |
| Laser Head Dimensions [ mm ]           | 135 [L] × 75 [W] × 45 [H]  |                       |
| Power Supply Dimensions [ mm ]         | 130 [L] × 120 [W] × 55 [H] |                       |
| Working Voltage [ VAC ]                | 85~245, 50/60Hz            |                       |
| Laser Gross Weight [ kg ]              | 1.5                        |                       |
| Cooling Way                            | Cooled by TEC and air      |                       |
| Expected Lifetime [ hours ]            | > 10000                    |                       |
| Warranty Time [ year ]                 | 1                          |                       |

**Laser Head Dimension:**

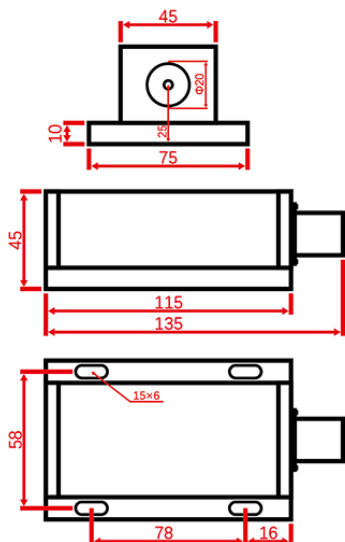

**Power Supply Dimension:**

